

THIS DRAWING IS UNPUBLISHED. RELEASED FOR PUBLICATION
 © COPYRIGHT - BY TYCO ELECTRONICS CORPORATION. ALL RIGHTS RESERVED.

LOC	DIST	REVISIONS					
H	-	P	LTR	DESCRIPTION	DATE	DWN	APVD
			A	REVISED PER ECR-15-016813	24NOV2015	RS	SZ

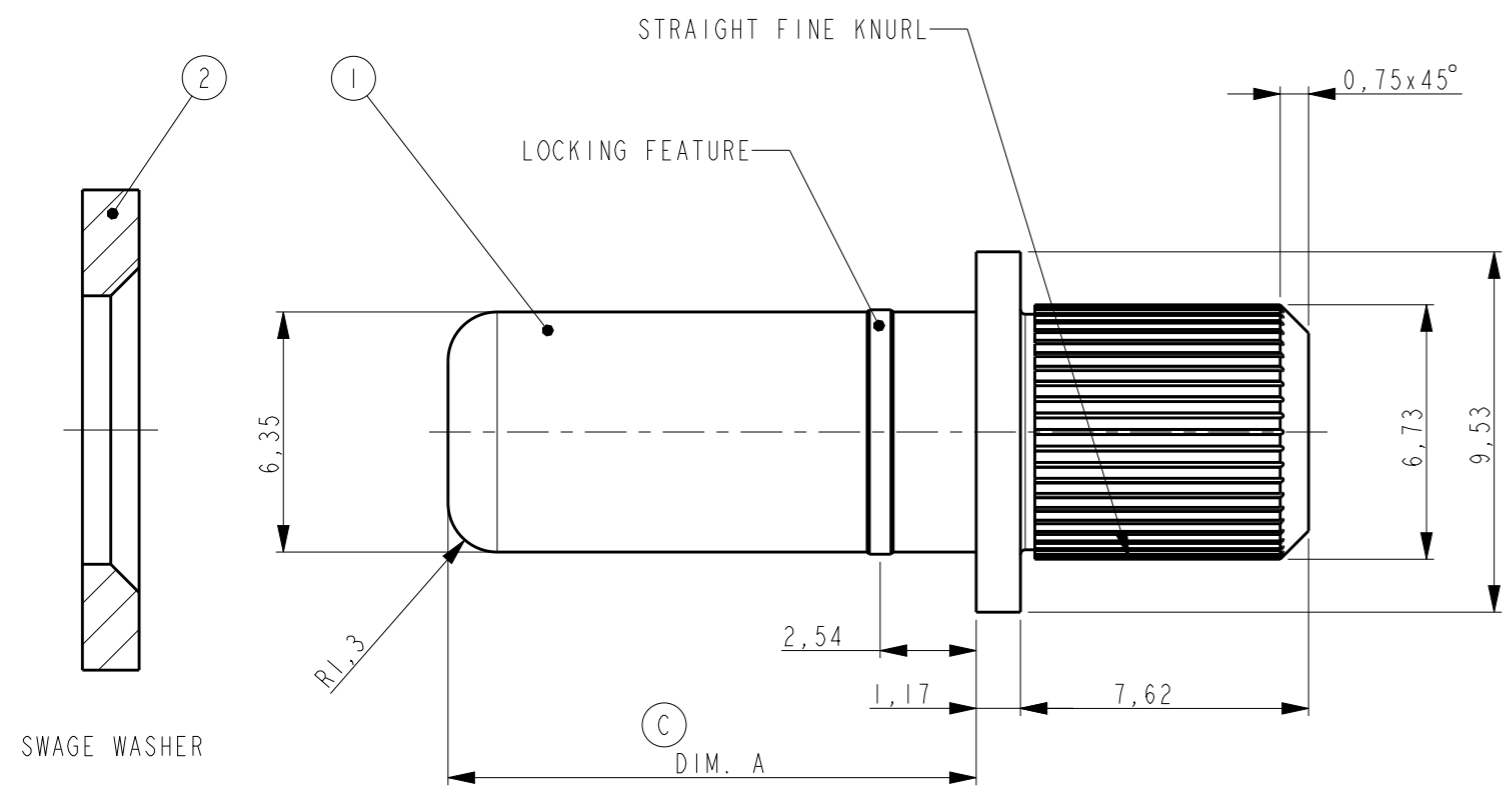

NOTES:

- PART NUMBER CHANGES AND/OR DESIGN CHANGES AFFECTING ITEM INTERCHANGEABILITY REQUIRE PRIOR TYCO ELECTRONICS APPROVAL AND AUTHORIZATION BY REVISION TO THIS DRAWING.
- ITEMS PROVIDED TO THIS SPECIFICATION SHALL BE IDENTIFIED ON THE CONTAINER. WITH THE FOLLOWING INFORMATION: PART NUMBER&DATE CODE OF MANUFACTURE.
- MATERIAL: - PIN CONTACT : COPPER ALLOY
- SWAGE WASHER : STEEL.
- FINISH; -PIN CONTACT: SILVER 5,0μ MIN THK. OVER NICKEL 1,0μ MIN. THK.
- FINISH; -PIN CONTACT: GOLD 0,5μ MIN THK. OVER NICKEL 1,0μ MIN. THK.
- RECOMMENDED HOLE DIAMETER AFTER PLATING: ø6,60 +0,07 / -0,03
- RETAIN PIN CONTACT WITH SUPPORT TOOL BEFORE SWAGE OPERATION.

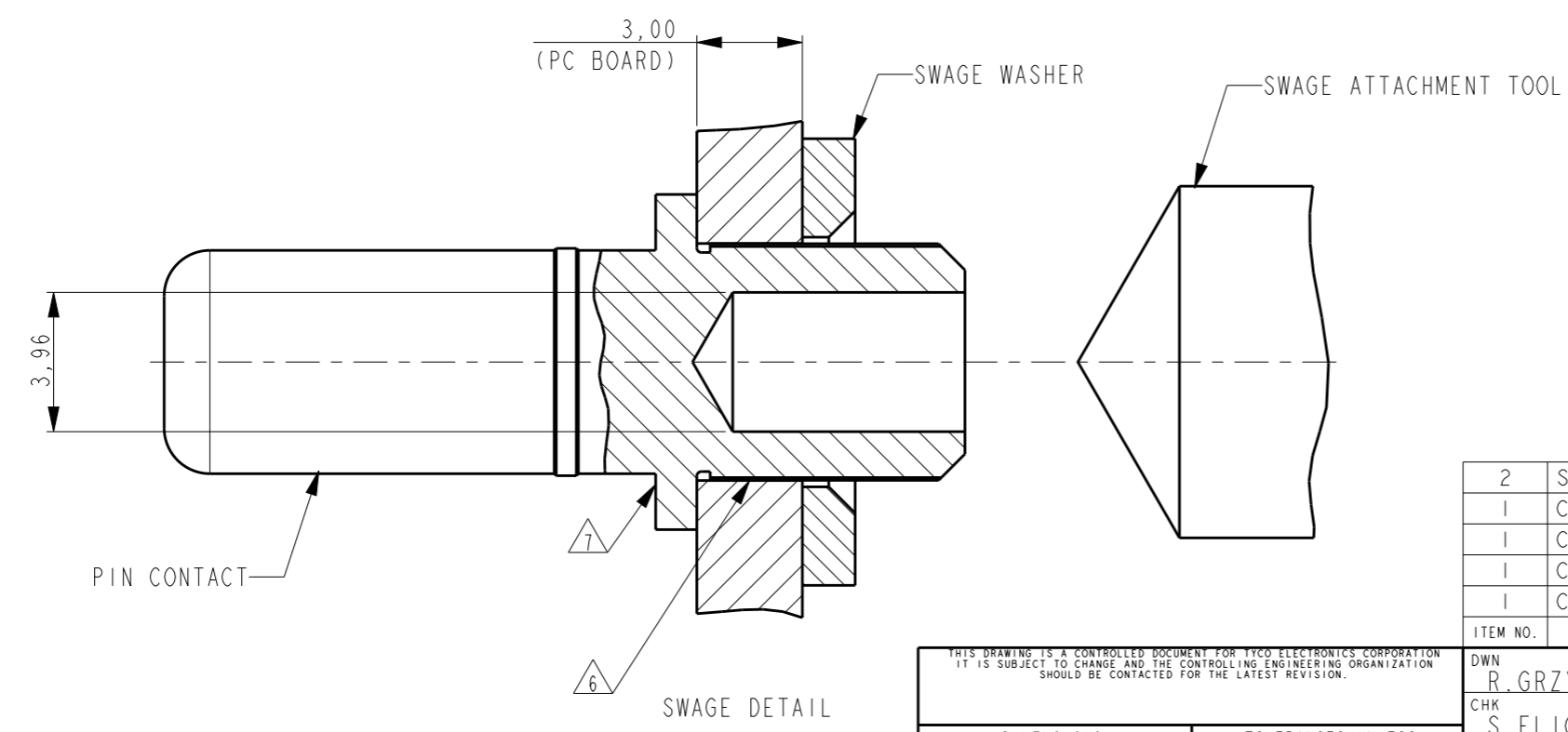

6648222-1	6648222-2	6648222-5	6648222-6
-----------	-----------	-----------	-----------

ITEM NO.	DESCRIPTION	MATERIAL	DIM. A	FINISH	QUANTITY
2	SWAGE WASHER 1,5MM THICK	STEEL			1
1	CONTACT PIN SIZE #4	COPPER ALLOY	11.68	5	1
1	CONTACT PIN SIZE #4	COPPER ALLOY	11.68	4	1
1	CONTACT PIN SIZE #4	COPPER ALLOY	13.97	5	1
1	CONTACT PIN SIZE #4	COPPER ALLOY	13.97	4	1

THIS DRAWING IS A CONTROLLED DOCUMENT FOR TYCO ELECTRONICS CORPORATION IT IS SUBJECT TO CHANGE AND THE CONTROLLING ENGINEERING ORGANIZATION SHOULD BE CONTACTED FOR THE LATEST REVISION.

DIMENSIONS:	TOLERANCES UNLESS OTHERWISE SPECIFIED:
mm	0 PLC ±-
	1 PLC ±-
	2 PLC ±-
	3 PLC ±-
	4 PLC ±-
	ANGLES ±-
MATERIAL -	FINISH -

DWN 04APR2008 R.GRZYBOWSKI
 CHK 03APR06 S.FLICKINGER
 APVD 03APR06 S.FLICKINGER

Tyco Electronics Tyco Electronics Corporation
 's-Hertogenbosch, Nederland

NAME: PIN CONTACT, SIZE NO.4
 SWAGE MOUNT
 LOCKING STYLE, PRESS FIT

SIZE: A3 CAGE CODE: 00779 DRAWING NO: C-6648222 RESTRICTED TO: -

CUSTOMER DRAWING SCALE: SHEET OF REV C